

NETWORK COMPATIBLE RELAY / CURRENT SENSOR COMBOS

RIBMW24SB-LNAI

4.00" Track Mount LonWorks® Twisted-Pair FT-10 Network Three I/O Device; One Binary Output (20 Amp Relay SPST + Override), One Binary Input (Dry Contact, Class 2); One Analog Input (0-5Vdc / 0-10 Vdc); 24 Vac/dc Power Input

RIBTW24SB-LNAI

Enclosed LonWorks® Twisted-Pair FT-10 Network Enclosed Three I/O Device; One Binary Output (20 Amp Relay SPST + Override), One Binary Input (Dry Contact, Class 2); One Analog Input (0-5Vdc / 0-10 Vdc); 24 Vac/dc Power Input.

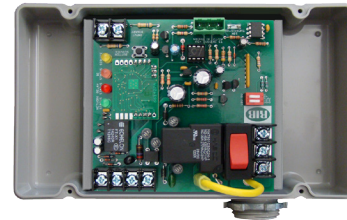
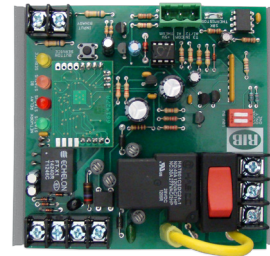
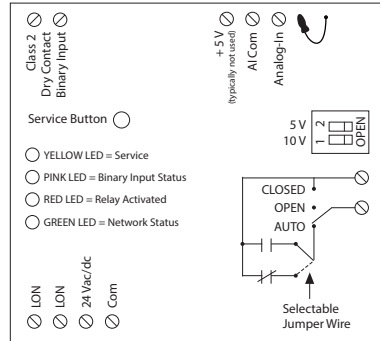
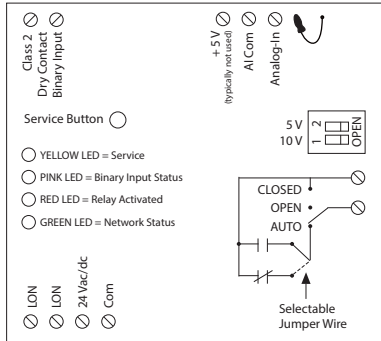

RELAYS

SPECIFICATIONS

- # Relays & Contact Type:** One (1) SPST Continuous Duty Coil
- Expected Relay Life:** 10 million cycles minimum mechanical
- Operating Temperature:** -30 to 140° F
- Humidity Range:** 5 to 95% (noncondensing)
- Operate Time:** 18ms
- Green LED:** Network Status
- Red LED:** Relay Status
- Yellow LED:** Service Status
- Pink LED:** Binary Input Status
- Dimensions:** 4.00" x 4.00" x 1.50" (RIBMW24SB-LNAI)
4.28" x 7.00" x 2.00" with .75" NPT Nipple (RIBTW24SB-LNAI)
- Track Mount:** MT4-4 Mounting Track Provided
- Approvals:** FCC, LonMark®, CE, RoHS
UL Listed, UL916, C-UL
- Housing Rating:** UL Listed, NEMA 1, C-UL, CE Approved,
UL Accepted for Use in Plenum,
Also available NEMA 4 / 4X
- Gold Flash:** No
- Override Switch:** Yes
- Channel:** TP/FT-10
- Transceiver Type:** FT5000 Smart Transceiver
- Transceiver Compatibility:** FT3120 / FT3150, FTT-10 / FTT-10A, and
LPT-10 / LPT-11 Transceivers
- Functional Blocks:** 0000 Node Object
0004 Closed Loop Actuator Object
0001 Open Loop Sensor Object
0520 Analog Input
- Downloadable Files:** PDF, XIF, APB, VSS and NXE
available on website.

- Contact Ratings:**
20 Amp Resistive @ 277 Vac
20 Amp Ballast @ 120/277 Vac (N/O)
10 Amp Ballast @ 120/277 Vac (N/C)
Not rated for Electronic Ballast
10 Amp Tungsten @ 120 Vac (N/O)
1110 VA Pilot Duty @ 277 Vac
770 VA Pilot Duty @ 120 Vac
2 HP @ 277 Vac
1 HP @ 120 Vac

- Power Input Ratings:**
111 mA @ 24 Vac
81 mA @ 24 Vdc

- Power Input:**
24 Vac/dc ; 50-60 Hz *

- Notes:**
 - Order with P1 option by adding "-P1" to end of model number. The P1 option is pre-programmed to allow dry contact binary input to command the relay. Contact closure on the BI will activate relay.
 - Normally Open or Normally Closed selected by yellow jumper wire.
 - Order NEMA 4 housing by adding "-N4" to end of model number. (RIBTW24SB-LNAI-N4)
 - Close DIP switch 1 for 0-5 Vdc Analog Input. Close DIP switch 2 for 0-10 Vdc Analog Input.
 - When connecting 24 Vac to both the RIB(s) and a half-wave device, damage to device can occur. Option 1: Use separate transformers for each device. Option 2: Add diode between devices, see Option 2 note below. ^^
 - See page 71 for -LNT2 or -LNT3 models if using a thermistor. If using a thermistor on the Analog Input, set DIP switches to the 0-5 Vdc setting. A look-up table must also be made.

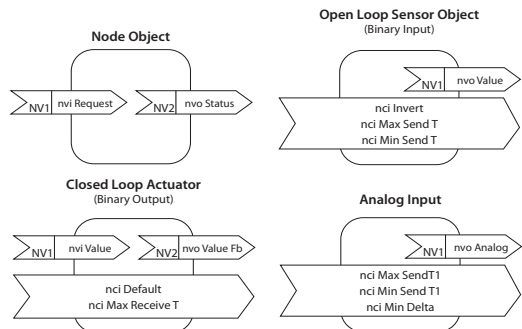

DESCRIPTION	SNVT NAME	SNVT TYPE
Command to open/close relay	nvi Value	SNVT_switch
Command status of relay	nvo Value Fb	SNVT_switch
Default state of relay on/off	nci Default	SNVT_switch
Communication timer	nci Max Receive T	SNVT_elapsed_tm
Status of Binary Input	nvo Value	SNVT_switch
Invert status of Binary Input	nci Invert	SNVT_lev_disc
Max time between updates	nci Max Send T	SNVT_elapsed_tm
Min time between updates	nci Min Send T	SNVT_elapsed_tm
Value of Analog-In	nvo Analog	SNVT_lev_percent
Max time between Analog updates	nci Max Send T1	SNVT_elapsed_tm
Min time between Analog updates	nci Min Send T1	SNVT_elapsed_tm
Min change in Analog before updates	nci Min Delta	SNVT_lev_percent

The relay will go to the default state when the communication timer times out. Setting the timer value to zero will cause the communication to never time out.

It is recommended to put a value in nci Max Send T to ensure the RIB re-synchronizes itself on the network after power loss. It is the responsibility of the user to ensure this value does not cause conflicts in network traffic. (No value = No "heartbeat" updates / no re-synchronization; Low Value = Many updates but may cause many traffic collisions; High value = Few updates but many less collisions.)

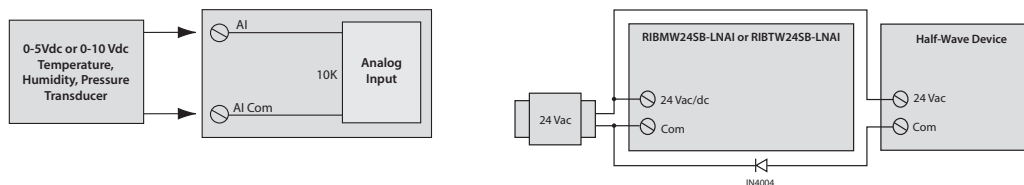

^^ Option 2: Add diode on 24 Vac power (Com) interconnection between devices. Band on diode faces towards RIB(s).