



---

# Suction Diffuser Plus

---



---

# Table of Contents

<b>Introduction and Safety</b> .....	<b>2</b>
Introduction.....	2
Safety.....	2
Safety terminology and symbols.....	2
User safety.....	3
Environmental safety.....	4
<b>Transportation and Storage</b> .....	<b>6</b>
Inspect the delivery.....	6
Inspect the package.....	6
Inspect the unit.....	6
<b>Product Description</b> .....	<b>7</b>
General description.....	7
Operation specifications.....	8
<b>Installation</b> .....	<b>9</b>
Installation guidelines.....	9
<b>Operation</b> .....	<b>12</b>
Operation guidelines.....	12
<b>Maintenance</b> .....	<b>14</b>
Inspect the orifice cylinder.....	14
Service the suction diffuser plus.....	14
Service P/T ports or drain plugs.....	14
<b>Product warranty</b> .....	<b>16</b>

# Introduction and Safety

## Introduction

### Purpose of this manual

The purpose of this manual is to provide necessary information for:

- Installation
- Operation
- Maintenance



---

#### CAUTION:

Read this manual carefully before installing and using the product. Improper use of the product can cause personal injury and damage to property, and may void the warranty.

---

---

#### NOTICE:

Save this manual for future reference, and keep it readily available at the location of the unit.

---

## Safety



---

#### WARNING:

- The operator must be aware of safety precautions to prevent physical injury.
  - Operating, installing, or maintaining the unit in any way that is not covered in this manual could cause death, serious personal injury, or damage to the equipment. This includes any modification to the equipment or use of parts not provided by Xylem. If there is a question regarding the intended use of the equipment, please contact a Xylem representative before proceeding.
  - Do not change the service application without the approval of an authorized Xylem representative.
- 



---

#### CAUTION:

You must observe the instructions contained in this manual. Failure to do so could result in physical injury, damage, or delays.

---



## Safety terminology and symbols

### About safety messages

It is extremely important that you read, understand, and follow the safety messages and regulations carefully before handling the product. They are published to help prevent these hazards:

- Personal accidents and health problems
- Damage to the product
- Product malfunction

## Hazard levels

Hazard level	Indication
 <b>DANGER:</b>	A hazardous situation which, if not avoided, will result in death or serious injury
 <b>WARNING:</b>	A hazardous situation which, if not avoided, could result in death or serious injury
 <b>CAUTION:</b>	A hazardous situation which, if not avoided, could result in minor or moderate injury
<b>NOTICE:</b>	<ul style="list-style-type: none"> <li>• A potential situation which, if not avoided, could result in undesirable conditions</li> <li>• A practice not related to personal injury</li> </ul>

## Hazard categories

Hazard categories can either fall under hazard levels or let specific symbols replace the ordinary hazard level symbols.

Electrical hazards are indicated by the following specific symbol:



**Electrical Hazard:**

These are examples of other categories that can occur. They fall under the ordinary hazard levels and may use complementing symbols:

- Crush hazard
- Cutting hazard
- Arc flash hazard

## User safety

### General safety rules

These safety rules apply:

- Always keep the work area clean.
- Pay attention to the risks presented by gas and vapors in the work area.
- Avoid all electrical dangers. Pay attention to the risks of electric shock or arc flash hazards.
- Always bear in mind the risk of drowning, electrical accidents, and burn injuries.

### Safety equipment

Use safety equipment according to the company regulations. Use this safety equipment within the work area:

- Hard hat
- Safety goggles, preferably with side shields
- Protective shoes
- Protective gloves
- Gas mask
- Hearing protection

- First-aid kit
- Safety devices

**NOTICE:**

Never operate a unit unless safety devices are installed. Also see specific information about safety devices in other chapters of this manual.

**Electrical connections**

Electrical connections must be made by certified electricians in compliance with all international, national, state, and local regulations. For more information about requirements, see sections dealing specifically with electrical connections.

**Precautions before work**

Observe these safety precautions before you work with the product or are in connection with the product:

- Provide a suitable barrier around the work area, for example, a guard rail.
- Make sure that all safety guards are in place and secure.
- Make sure that you have a clear path of retreat.
- Make sure that the product cannot roll or fall over and injure people or damage property.
- Make sure that the lifting equipment is in good condition and is properly sized for the load to be lifted.
- Use a lifting harness and safety line, as required.
- Allow all system components to cool before you handle them.
- Make sure that the product has been thoroughly cleaned.
- Disconnect and lock out power before you install or service the suction diffuser.
- Check the explosion risk before you weld or use electric hand tools.

**Wash the skin and eyes**

Follow these procedures for chemicals or hazardous fluids that have come into contact with your eyes or your skin:

Condition	Action
Chemicals or hazardous fluids in eyes	<ol style="list-style-type: none"> <li>1. Hold your eyelids apart forcibly with your fingers.</li> <li>2. Rinse the eyes with eyewash or running water for at least 15 minutes.</li> <li>3. Seek medical attention.</li> </ol>
Chemicals or hazardous fluids on skin	<ol style="list-style-type: none"> <li>1. Remove contaminated clothing.</li> <li>2. Wash the skin with soap and water for at least 1 minute.</li> <li>3. Seek medical attention, if necessary.</li> </ol>

**Environmental safety****The work area**

Always keep the station clean.

**Waste and emissions regulations**

Observe these safety regulations regarding waste and emissions:

- Appropriately dispose of all waste.
- Handle and dispose of the processed liquid in compliance with applicable environmental regulations.
- Clean up all spills in accordance with safety and environmental procedures.
- Report all environmental emissions to the appropriate authorities.



---

**CAUTION: Radiation Hazard**

Do NOT send the product to Xylem if it has been exposed to nuclear radiation, unless Xylem has been informed and appropriate actions have been agreed upon.

---

**Electrical installation**

For electrical installation recycling requirements, consult your local electric utility.

**Recycling guidelines**

Always follow local laws and regulations regarding recycling.

# Transportation and Storage

## Inspect the delivery

### Inspect the package

1. Inspect the package for damaged or missing items upon delivery.
2. Note any damaged or missing items on the receipt and freight bill.
3. File a claim with the shipping company if anything is out of order.  
If the product has been picked up at a distributor, make a claim directly to the distributor.

### Inspect the unit

1. Remove packing materials from the product.  
Dispose of all packing materials in accordance with local regulations.
2. Inspect the product to determine if any parts have been damaged or are missing.
3. If applicable, unfasten the product by removing any screws, bolts, or straps.  
For your personal safety, be careful when you handle nails and straps.
4. Contact the local sales representative if there is any issue.



---

# Product Description

## General description

The Suction Diffuser Plus is an angle pattern flow straightening fitting that combines a diffuser-strainer orifice cylinder and full length straightening vanes to provide ideal flow conditions for the pump suction. It saves space and money by eliminating the need for long or short radius elbows, reducing flanges, and long lengths of pipe leading into the suction side of the pump.

The Suction Diffuser Plus is designed for direct application to the pump suction and provides ideal flow conditions for the pump, providing NPSH requirements are met.

The main features are:

- The integrated Flow Cone directs flow through the unit and into the pump suction while working with the full length straightening vanes to create a uniform flow profile.
- The orifice cylinder has a free area equal to five times the cross section of the pump suction opening and serves as a coarse strainer to protect the pump from large sediment.
- A disposable fine mesh bronze start-up strainer is provided in conjunction with the orifice cylinder to help protect the pump and clean the system by capturing small particles and other debris during system commissioning.

The operation chapter of this manual contains data showing pressure drop conditions across the Suction Diffuser Plus both with and without the mesh start-up strainer in place.

In order to determine the presence of the start-up strainer in a non-intrusive manner, gauge ports, or taps, are located in the inlet and outlet flanges of the Suction Diffuser Plus.

### Parts included in package

- Suction Diffuser Plus
- Instruction Manual

### Additional parts needed:

- Flange gaskets
- Nuts and bolts
- Foot support
- Support leg



---

#### WARNING:

California Proposition 65 warning! This product contains chemicals known to the state of California to cause cancer and birth defects or other reproductive harm.

---

#### NOTICE:

This product is not intended for potable water applications.

---

### Declaration of Conformity

Xylem Inc. declares that the product listed conforms with the essential requirements and provisions of Council Directive 97/23/EC, has been subject to internal manufacturing checks with monitoring of the quality system, and conforms to following Sound Engineering Practices (SEP) for use with Group 2 (non-hazardous) liquids. The suction diffusers are not suitable for use with Group 1 (hazardous) liquids.

## Operation specifications

Type	Maximum working pressure	Maximum operating temperature
Pump connection flanged or NPT and system connection flanged, NPT, or grooved	175 psi (1207 kPa)	121°C (250°F)
Pump connection grooved with adapter flange and system connection grooved	300 psi (2069 kPa)	121°C (250°F)

# Installation

## Installation guidelines

---

**WARNING:**

All procedures must be performed by qualified personnel.

---

- Before selecting a location for the pump Suction Diffuser Plus, make sure that there is enough room to remove the Suction Diffuser Plus orifice cylinder. The length requirements are Shown as Dimension "A" in the following table.
- If the pump pad is resilient mounted (rubber or spring), make sure that the pad is large enough to include an adjustable Suction Diffuser Plus support leg.
- A support leg, not furnished, is required between the Suction Diffuser Plus and the support foot, not furnished, to support the Suction Diffuser Plus and prevent strain on the pump. Bosses are provided on the Suction Diffuser to locate the support leg and facilitate mounting the Suction Diffuser Plus in any of three positions. The length of the support leg varies depending on the pump centerline to mounting surface dimension. The support leg can be made of Schedule 40 pipe. Refer to column "D" in the following table for the required diameter of the support leg. Final height adjustment is made with the adjustable support foot.
- When installing flanged model Suction Diffuser Plus , a criss-cross pattern should be used when tightening the bolts. If PTFE tape is used when installing cast iron NPT Models, be careful not to overtighten the connections. Cracks may develop in the casting.
- Suction Diffuser Plus blowdown is best accomplished with the system connection in the 12 o'clock position. Blowdown is less effective with the system connection in the 3 and 9 o'clock positions.
- When insulating the Suction Diffuser Plus after system installation, provisions should be made to permit removal of the start-up strainer, orifice cylinder, and inlet vane assembly.
- It is recommended that a pressure-vacuum gauge be installed in the integral 1/4" NPT tapping to monitor pump inlet pressure.

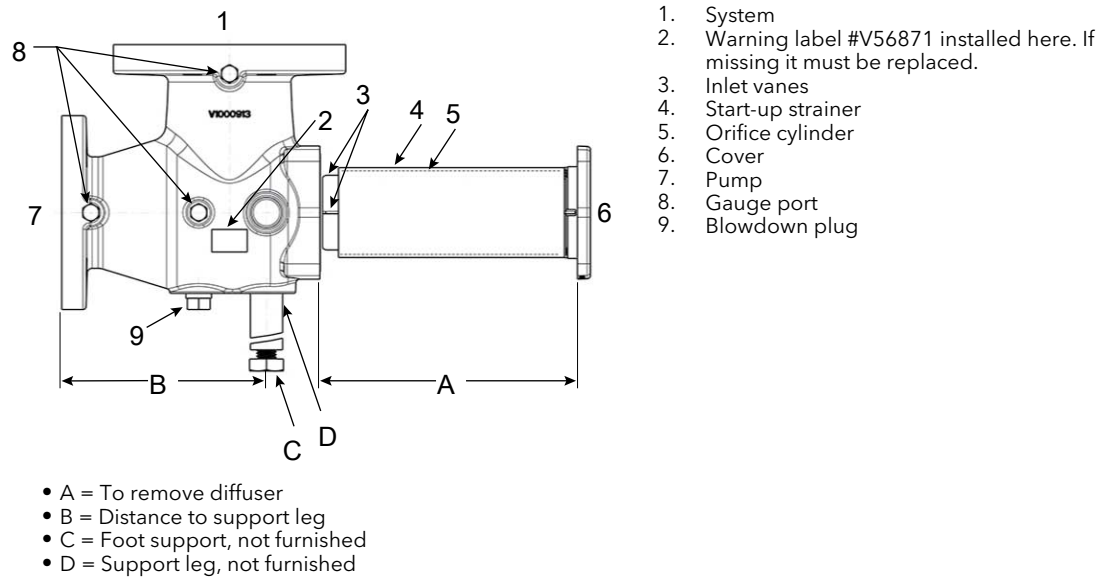

Figure 1: Working pressure 175 PSI (1207 KPa), 121°C (250°F)

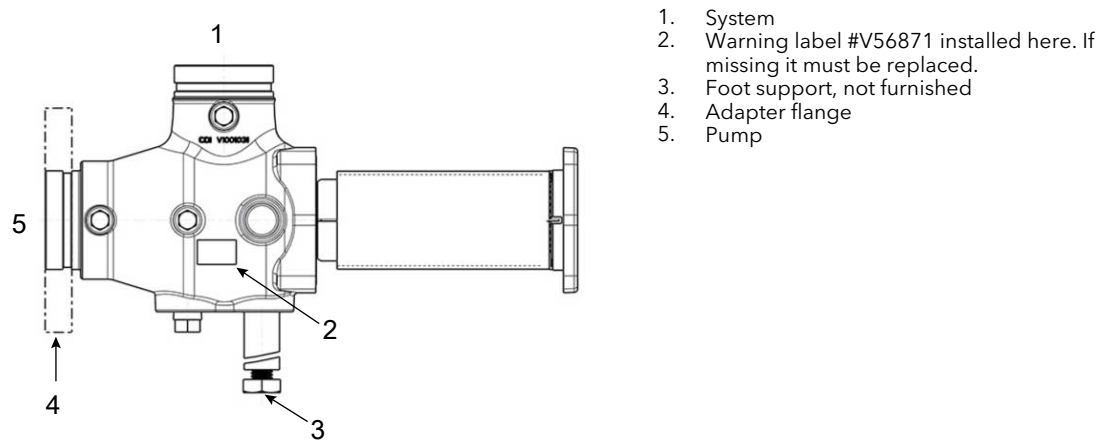

Figure 2: Working pressure 300 PSI (2069 KPa), 121°C (250°F)

Size	Model Number	Dimensions in inches (mm)			
		A	B	Part Number C	Schedule 40 Diameter D
2x1.5	BA-3	5.15 (130.8)	3.81 (96.8)	A90982	3/4" (19.1)
2x2	BB-3	6.75 (171.5)	4.38 (111.3)	A90982	3/4" (19.1)
2.5x2	CB-3	6.75 (171.5)	4.38 (111.3)	A90982	3/4" (19.1)
2.5x2.5	CC-3	7.63 (193.7)	5.77 (146.6)	A90982	3/4" (19.1)
2.5x2.5 GXF	SDG-2.5	7.63 (193.7)	6.60 (167.6)	A90982	3/4" (19.1)
3x1.5	DA-3	6.63 (168.3)	4.38 (111.3)	A90982	3/4" (19.1)
3x2	DB-3	6.75 (171.5)	4.38 (111.3)	A90982	3/4" (19.1)
3x2.5	DC-3	7.63 (193.7)	5.77 (146.6)	A90982	3/4" (19.1)
4x2.5	EC-3	7.63 (193.7)	5.77 (146.6)	A90982	3/4" (19.1)
3x3	DD-3	8.75 (222.3)	7.02 (178.3)	A90883	1-1/4" (31.8)
3x3 GXF	SDG-3	8.75 (222.3)	7.66 (194.6)	A90883	1-1/4" (31.8)
4x3	ED-3	10.00 (254.0)	7.93 (201.4)	A90883	1-1/4" (31.8)

Size	Model Number	Dimensions in inches (mm)			
		A	B	Part Number C	Schedule 40 Diameter D
4x4	EE-3	10.69 (271.5)	7.87 (199.9)	A90883	1-1/4" (31.8)
4x4 GXF	SDG-4	10.69 (271.5)	8.75 (222.3)	A90883	1-1/4" (31.8)
5x4	FE-3	10.69 (271.5)	7.87 (199.9)	A90883	1-1/4" (31.8)
5x5	FF-3	12.84 (326.1)	10.44 (265.2)	A90883	1-1/4" (31.8)
5x5 GXF	SDG-5	12.84 (326.1)	11.05 (280.7)	A90883	1-1/4" (31.8)
6x4	GE-3	10.69 (271.5)	7.87 (199.9)	A90883	1-1/4" (31.8)
6x5	GF-3	13.85 (351.5)	10.46 (265.7)	A90883	1-1/4" (31.8)
6x6	GG-3	14.75 (374.7)	10.99 (279.1)	A90883	1-1/4" (31.8)
6x6 GXF	SDG-6	14.75 (374.7)	12.00 (304.8)	A90883	1-1/4" (31.8)
8x6	HG-3	14.75 (374.7)	10.99 (279.1)	A90883	1-1/4" (31.8)
8x8	HH-3	18.25 (463.6)	12.62 (320.5)	A90883	1-1/4" (31.8)
8x8 GXF	SDG-8	18.25 (463.6)	13.87 (352.3)	A90883	1-1/4" (31.8)
10x8	JH-3	18.25 (463.6)	12.62 (320.5)	A90883	1-1/4" (31.8)
10x10	JJ-3	21.50 (546.1)	15.68 (398.3)	A90883	1-1/4" (31.8)
10x10	SDG-10	21.50 (546.1)	16.02 (406.9)	A90883	1-1/4" (31.8)

#### FOR PIPE HANGING INSTALLATIONS

Be aware of water weight in the Suction Diffuser Plus and connected piping when installing your system.

---

#### NOTICE:

Never use the suction diffuser itself as a form of piping support. Support suction diffusers, valves, and piping according to the local building code. Failure to follow these instructions may result in property damage.

---

# Operation

## Operation guidelines

### Initial operation

The start-up strainer must be removed from the Suction Diffuser Plus within 24 to 48 hours after the initial circulation and cleaning of the system. If left in place, a noticeable increase in pressure drop will be observed as the fine strainer becomes clogged and starts restricting flow through the Suction Diffuser Plus. See [Service the suction diffuser plus](#) (page 14) in the Maintenance chapter of this manual for instructions for the removal of this strainer.

Measure the pressure drop across the flange gauge ports on the inlet and outlet of the Suction Diffuser Plus and, using the corresponding pump flow, compare the pressure drop values with those published in section [Pressure drop charts](#) (page 12).

- If the measured pressure drop matches the higher pressure drop for the corresponding flow shown in the submittal, this indicates that the start-up strainer is still in place and should be removed. Follow the instructions in [Service the suction diffuser plus](#) (page 14) in the Maintenance chapter of this manual to inspect the orifice cylinder and remove any blockage that may be present.
- If the measured pressure drop matches the lower pressure drop value in the submittal, this indicates that the strainer has already been removed.

### Pressure drop charts

Performance characteristics measured using integrated PT ports with and without start-up strainer.

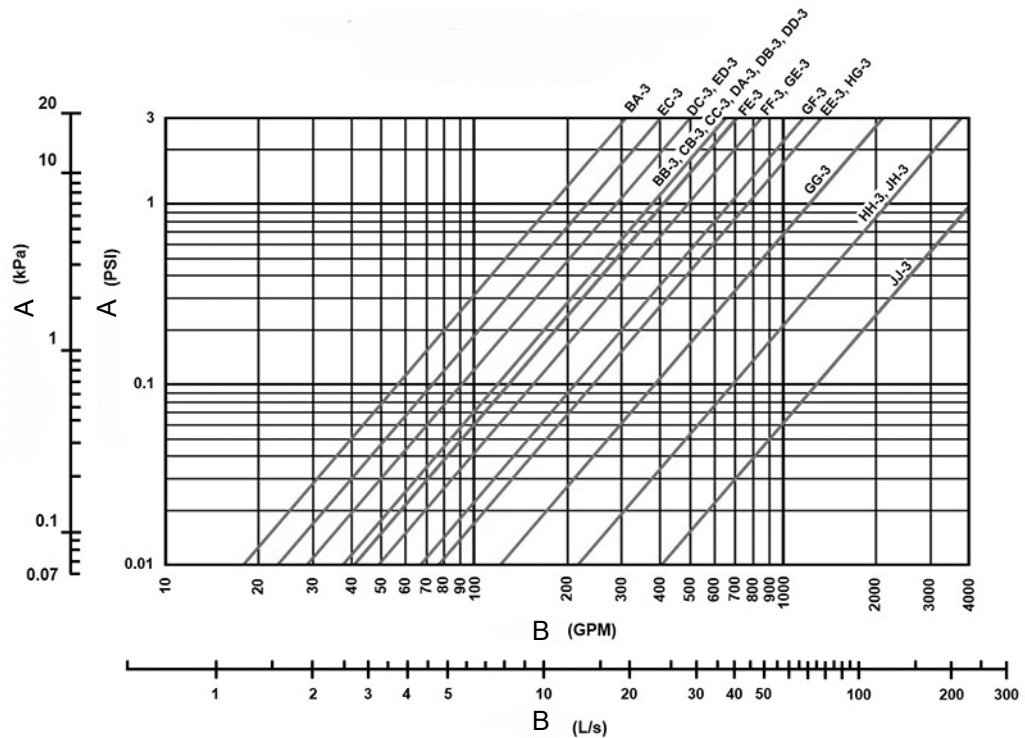
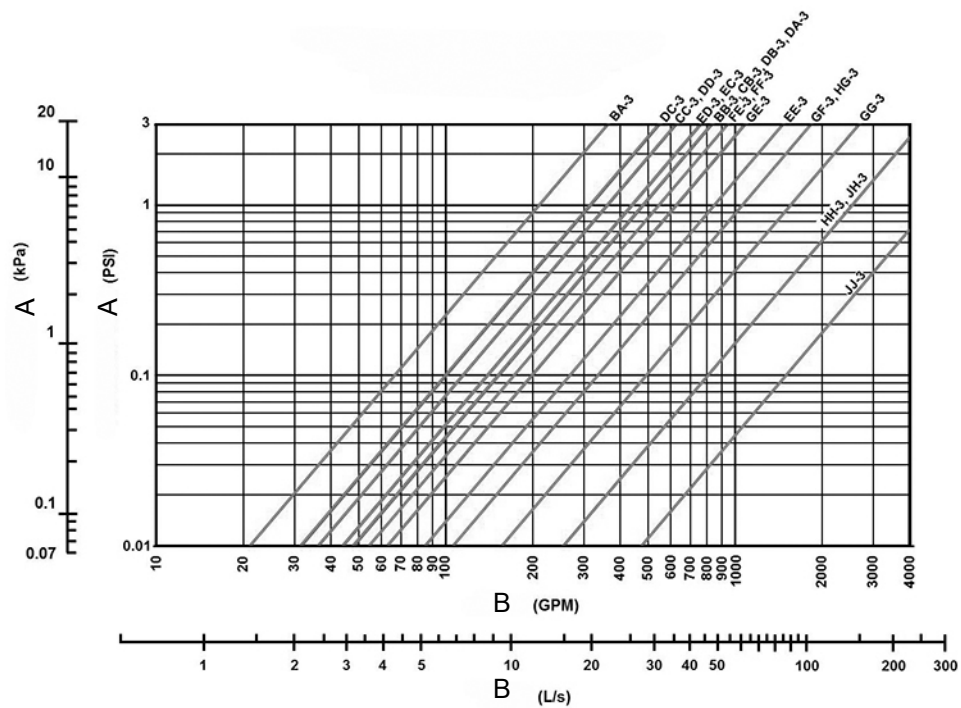

Figure 3: With start-up strainer



- A = Pressure drop
- B = Flow

Figure 4: Without start-up strainer

### Continued operation

During system operation, measure the pressure drop across the inlet and outlet flanges of the Suction Diffuser Plus and compare the data with the published pressure drop information to detect if any blockage is present within the suction diffuser Plus. If the measured data matches the higher pressure drop value for the system flow, there may be a blockage inside.

Follow the instructions in [Service the suction diffuser plus](#) (page 14) in the Maintenance chapter of this manual to inspect the orifice cylinder and remove any blockage that may be present.

A pressure gauge installed in one of the Gauge ports of the Suction Diffuser Plus can also warn of a blockage.

---

#### NOTICE:

Potential pump damage. Blockage in the suction diffuser can cause serious damage due to cavitation within the pump. NPSH requirements for the pump must be met and maintained. Periodically verify the pressure drop across the suction diffuser and inspect the orifice strainer to prevent blockages that can cause cavitation. Failure to follow these instructions could result in property damage.

---

# Maintenance

## Inspect the orifice cylinder

Periodic inspection of inlet vanes and cleaning of the orifice cylinder is required to guard against damage to the pump. If damaged, they must be replaced.

## Service the suction diffuser plus

Periodically inspect the Suction Diffuser Plus for signs of leakage or corrosion.



---

### WARNING:

Risk for property damage, serious personal injury or death. You must replace the suction diffuser if corrosion or leakage is found.

---

To service and inspect the Suction Diffuser Plus, complete the following steps:

1. Shut the pump off and isolate the Suction Diffuser Plus and pump from the system.
2. Allow system temperature to cool to below 38°C (100°F) to reach a safe handling temperature.



---

### WARNING:

High temperature and pressure hazard. Make sure that system temperature is below 38°C (100°F) and system pressure is reduced and maintained at zero before servicing the unit.

---

3. Open a drain valve in the isolated Suction Diffuser Plus piping and allow system pressure to drop to zero. If fluid continues to flow from the drain valve, repack or replace the isolation valves before proceeding.
4. Loosen the screws that secure the Suction Diffuser Plus cover and break it loose from the body. Make certain all drainage stops before removing the screws and cover.
5. Grasp the inlet vane assembly with pliers and pull it out of the Suction Diffuser Plus Body.
6. Remove start up strainer if still in place and inspect the orifice cylinder and inlet vane assembly for damage. Replace damaged components with new components as required.
7. Inspect the O-ring seal and replace with new component as required.
8. Reassemble the Suction Diffuser Plus and secure the cover with a criss-cross tightening pattern.
9. Open isolation valves slowly and inspect the gasket area for leaks.
10. Return system to normal operation.

## Service P/T ports or drain plugs

The P/T readout ports and drain plugs come pre-assembled with a leading industrial thread sealant, Loctite, and are tightened to appropriate levels. Any field adjustment of factory installed components breaks the original thread seal and could cause leakage. This adjustment necessitates the removal, cleaning, and resealing of those parts per the following instructions.

1. Remove the desired component from the Suction Diffuser Plus.
2. Clean off all of the old thread sealant using a wire brush and gentle abrasion if necessary.



If the component or Suction Diffuser Plus appears to have been damaged, replace it.

3. Starting with the second thread of the male Suction Diffuser Plus component, apply a 360° bead of Loctite 567 thread sealant/lubricant as shown. Follow Loctite handling precautions as noted on the product label.



4. If Loctite is not available, it is recommended that you use RectorSeal No. 5 pipe thread sealant for all non-glycol based applications, or any PTFE thread sealing tape. Be sure to follow the manufacturer-specific handling precaution and application instructions as noted on the product label.
5. Thread component into the Suction Diffuser Plus until it is finger tight.
6. Thread component into the valve until it is finger tight.
7. Apply torque to the following specification:

Size	Type	Torque, ft-lbs	Torque, Nm
1/4"	P/T Readout Port	9.0 ft-lbs. + 3.0 ft-lbs. / 0	12.2 Nm + 4.1 Nm / 0
3/4"	Drain plug	72.0 ft-lbs. + 21.0 ft-lbs. / 0	97.6 Nm + 28.5 Nm / 0

**NOTICE:**

The use of thread sealants and lubricants on threads also provides lubricity. Over-application of torque can damage the Suction Diffuser Plus port or component.

8. Properly assembled Suction Diffuser Plus components will immediately seal to moderate pressure (6 bar [100 PSI] or less). For maximum pressure resistance, allow the Loctite 567<sup>1</sup> or RectorSeal No. 5<sup>2</sup> thread sealant to cure for 24 hours. PTFE tape typically does not require curing to achieve maximum pressure resistance.

<sup>1</sup> Loctite and Loctite 567 are registered trademarks of Henkel Ag & Co.

<sup>2</sup> RectorSeal No.5 is a registered trademark of RectorSeal Corporation.

# Product warranty

## Commercial warranty

**Warranty.** For goods sold to commercial buyers, Seller warrants the goods sold to Buyer hereunder (with the exception of membranes, seals, gaskets, elastomer materials, coatings and other "wear parts" or consumables all of which are not warranted except as otherwise provided in the quotation or sales form) will be (i) be built in accordance with the specifications referred to in the quotation or sales form, if such specifications are expressly made a part of this Agreement, and (ii) free from defects in material and workmanship for a period of one (1) year from the date of installation or eighteen (18) months from the date of shipment (which date of shipment shall not be greater than thirty (30) days after receipt of notice that the goods are ready to ship), whichever shall occur first, unless a longer period is specified in the product documentation (the "Warranty").

Except as otherwise required by law, Seller shall, at its option and at no cost to Buyer, either repair or replace any product which fails to conform with the Warranty provided Buyer gives written notice to Seller of any defects in material or workmanship within ten (10) days of the date when any defects or non-conformance are first manifest. Under either repair or replacement option, Seller shall not be obligated to remove or pay for the removal of the defective product or install or pay for the installation of the replaced or repaired product and Buyer shall be responsible for all other costs, including, but not limited to, service costs, shipping fees and expenses. Seller shall have sole discretion as to the method or means of repair or replacement. Buyer's failure to comply with Seller's repair or replacement directions shall terminate Seller's obligations under this Warranty and render the Warranty void. Any parts repaired or replaced under the Warranty are warranted only for the balance of the warranty period on the parts that were repaired or replaced. Seller shall have no warranty obligations to Buyer with respect to any product or parts of a product that have been: (a) repaired by third parties other than Seller or without Seller's written approval; (b) subject to misuse, misapplication, neglect, alteration, accident, or physical damage; (c) used in a manner contrary to Seller's instructions for installation, operation and maintenance; (d) damaged from ordinary wear and tear, corrosion, or chemical attack; (e) damaged due to abnormal conditions, vibration, failure to properly prime, or operation without flow; (f) damaged due to a defective power supply or improper electrical protection; or (g) damaged resulting from the use of accessory equipment not sold or approved by Seller. In any case of products not manufactured by Seller, there is no warranty from Seller; however, Seller will extend to Buyer any warranty received from Seller's supplier of such products.

**THE FOREGOING WARRANTY IS EXCLUSIVE AND IN LIEU OF ANY AND ALL OTHER EXPRESS OR IMPLIED WARRANTIES, GUARANTEES, CONDITIONS OR TERMS OF WHATEVER NATURE RELATING TO THE GOODS PROVIDED HEREUNDER, INCLUDING WITHOUT LIMITATION ANY IMPLIED WARRANTIES OF MERCHANTABILITY AND FITNESS FOR A PARTICULAR PURPOSE, WHICH ARE HEREBY EXPRESSLY DISCLAIMED AND EXCLUDED. EXCEPT AS OTHERWISE REQUIRED BY LAW, BUYER'S EXCLUSIVE REMEDY AND SELLER'S AGGREGATE LIABILITY FOR BREACH OF ANY OF THE FOREGOING WARRANTIES ARE LIMITED TO REPAIRING OR REPLACING THE PRODUCT AND SHALL IN ALL CASES BE LIMITED TO THE AMOUNT PAID BY THE BUYER FOR THE DEFECTIVE PRODUCT. IN NO EVENT SHALL SELLER BE LIABLE FOR ANY OTHER FORM OF DAMAGES, WHETHER DIRECT, INDIRECT, LIQUIDATED, INCIDENTAL, CONSEQUENTIAL, PUNITIVE, EXEMPLARY OR SPECIAL DAMAGES, INCLUDING BUT NOT LIMITED TO LOSS OF PROFIT, LOSS OF ANTICIPATED SAVINGS OR REVENUE, LOSS OF INCOME, LOSS OF BUSINESS, LOSS OF PRODUCTION, LOSS OF OPPORTUNITY OR LOSS OF REPUTATION.**

---

## Consumer warranty

**Warranty.** For goods sold for personal, family or household purposes, Seller warrants the goods purchased hereunder (with the exception of membranes, seals, gaskets, elastomer materials, coatings and other "wear parts" or consumables all of which are not warranted except as otherwise provided in the quotation or sales form) will be free from defects in material and workmanship for a period of one (1) year from the date of installation or eighteen (18) months from the product date code, whichever shall occur first, unless a longer period is provided by law or is specified in the product documentation (the "Warranty").

Except as otherwise required by law, Seller shall, at its option and at no cost to Buyer, either repair or replace any product which fails to conform with the Warranty provided Buyer gives written notice to Seller of any defects in material or workmanship within ten (10) days of the date when any defects or non-conformance are first manifest. Under either repair or replacement option, Seller shall not be obligated to remove or pay for the removal of the defective product or install or pay for the installation of the replaced or repaired product and Buyer shall be responsible for all other costs, including, but not limited to, service costs, shipping fees and expenses. Seller shall have sole discretion as to the method or means of repair or replacement. Buyer's failure to comply with Seller's repair or replacement directions shall terminate Seller's obligations under this Warranty and render this Warranty void. Any parts repaired or replaced under the Warranty are warranted only for the balance of the warranty period on the parts that were repaired or replaced. The Warranty is conditioned on Buyer giving written notice to Seller of any defects in material or workmanship of warranted goods within ten (10) days of the date when any defects are first manifest.

Seller shall have no warranty obligations to Buyer with respect to any product or parts of a product that have been: (a) repaired by third parties other than Seller or without Seller's written approval; (b) subject to misuse, misapplication, neglect, alteration, accident, or physical damage; (c) used in a manner contrary to Seller's instructions for installation, operation and maintenance; (d) damaged from ordinary wear and tear, corrosion, or chemical attack; (e) damaged due to abnormal conditions, vibration, failure to properly prime, or operation without flow; (f) damaged due to a defective power supply or improper electrical protection; or (g) damaged resulting from the use of accessory equipment not sold or approved by Seller. In any case of products not manufactured by Seller, there is no warranty from Seller; however, Seller will extend to Buyer any warranty received from Seller's supplier of such products.

**THE FOREGOING WARRANTY IS PROVIDED IN PLACE OF ALL OTHER EXPRESS WARRANTIES. ALL IMPLIED WARRANTIES, INCLUDING BUT NOT LIMITED TO THE IMPLIED WARRANTIES OF MERCHANTABILITY AND FITNESS FOR A PARTICULAR PURPOSE, ARE LIMITED TO ONE (1) YEAR FROM THE DATE OF INSTALLATION OR EIGHTEEN (18) MONTHS FROM THE PRODUCT DATE CODE, WHICHEVER SHALL OCCUR FIRST. EXCEPT AS OTHERWISE REQUIRED BY LAW, BUYER'S EXCLUSIVE REMEDY AND SELLER'S AGGREGATE LIABILITY FOR BREACH OF ANY OF THE FOREGOING WARRANTIES ARE LIMITED TO REPAIRING OR REPLACING THE PRODUCT AND SHALL IN ALL CASES BE LIMITED TO THE AMOUNT PAID BY THE BUYER FOR THE DEFECTIVE PRODUCT. IN NO EVENT SHALL SELLER BE LIABLE FOR ANY OTHER FORM OF DAMAGES, WHETHER DIRECT, INDIRECT, LIQUIDATED, INCIDENTAL, CONSEQUENTIAL, PUNITIVE, EXEMPLARY OR SPECIAL DAMAGES, INCLUDING BUT NOT LIMITED TO LOSS OF PROFIT, LOSS OF ANTICIPATED SAVINGS OR REVENUE, LOSS OF INCOME, LOSS OF BUSINESS, LOSS OF PRODUCTION, LOSS OF OPPORTUNITY OR LOSS OF REPUTATION.**

Some states do not allow limitations on how long an implied warranty lasts, so the above limitation may not apply to you. Some states do not allow the exclusion or limitation of incidental or consequential damages, so the above exclusions may not apply to you. This warranty gives you specific legal rights, and you may also have other rights which may vary from state to state.

To make a warranty claim, check first with the dealer from whom you purchased the product or call the following number for the name and location of the nearest dealer providing warranty service. For Goulds Water Technology contact 315-568-7123. For all other products, contact 847-966-3700.







# Xylem |'zīləm|

- 1) The tissue in plants that brings water upward from the roots
- 2) A leading global water technology company

We're 12,500 people unified in a common purpose: creating innovative solutions to meet our world's water needs. Developing new technologies that will improve the way water is used, conserved, and re-used in the future is central to our work. We move, treat, analyze, and return water to the environment, and we help people use water efficiently, in their homes, buildings, factories and farms. In more than 150 countries, we have strong, long-standing relationships with customers who know us for our powerful combination of leading product brands and applications expertise, backed by a legacy of innovation.

For more information on how Xylem can help you, go to [xylem.com](http://xylem.com)



Xylem Inc.  
8200 N. Austin Avenue  
Morton Grove IL 60053  
Tel: (847) 966-3700  
Fax: (847) 965-8379  
[www.bellgossett.com](http://www.bellgossett.com)

Visit our Web site for the latest version of this document and more information

The original instruction is in English. All non-English instructions are translations of the original instruction.

© 2014 Xylem Inc

Bell & Gossett is a trademark of Xylem Inc or one of its subsidiaries.